

**User's**  
Manual

# AZURE

COUNTER FLOW  
HEAT RECOVERY  
VENTILATION

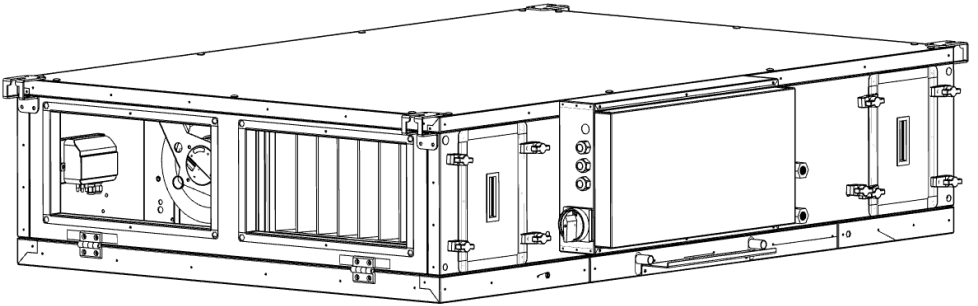

# CONTENTS

1.0 Important information .....	4	
1.1 Warning and safety instructions .....	4	
1.2 Warranty claims – Exclusion of liability .....	4	
1.3 Regulations – Guidelines .....	4	
1.4 Receipt .....	4	
1.5 Storage .....	5	
1.6 Transport .....	5	
1.7 Intended use .....	5	
1.8 Performance data .....	6	
1.9 Guideline series VDI 6022 .....	6	
1.10 Heat systems .....	6	
1.11 Technical data .....	6	
1.12 Disposal .....	7	
1.13 Disassembly and re-assembly .....	7	
<b>CHAPTER 2 INSTALLATION</b>		
2.0 Assembly .....	8	
2.1 Ceiling installation .....	8	
2.2 Condensation outlet .....	9	
2.3 Flange connection / adapter pieces .....	9	
2.4 Air ducting, Ventilation circuit .....	10	
2.5 Electrical Connection .....	10	
<b>CHAPTER 3 FUNCTIONAL DESCRIPTION</b>		
3.0 Unit Description .....	11	
3.1 Functional Diagram .....	12	
<b>CHAPTER 4 DIMENSIONS - PERFORMANCE CURVE</b>		
4.0 Dimensions .....	13	
4.1 Performance curves .....	15	
<b>CHAPTER 5 SERVICE AND MAINTENANCE</b>		
5.0 Service and maintenance .....	16	
5.1 Removing/cleaning cross counter flow heat exchanger .....	16	
5.2 Filter change .....	20	
5.3 Service and maintenance of fans .....	21	
5.4 Service and maintenance of pre-electrical heater .....	23	
5.5 Pre-electrical heater reset function .....	24	
5.6 Condensate tray .....	24	
5.7 Terminal box with isolator/main switch .....	25	
<b>CHAPTER 6 Installations, service and maintenance of accessories</b>		
6.1 Accessory list .....	26	
6.2 Installation of water after heater .....	29	
6.3 Installation of electrical after heater .....	31	
6.4 Installation of condensate pump .....	31	
<b>CHAPTER 7 WIRING DIAGRAM OVERVIEW</b>		
7.1 AZURE 500 wiring diagram .....	32	
7.2 AZURE 700 wiring diagram .....	35	
7.3 AZURE 1400 wiring diagram .....	38	
7.4 AZURE 2200 wiring diagram .....	41	
7.5 AZURE 3200 wiring diagram .....	44	
<b>CHAPTER 8 SPARE PART LIST .....</b>		<b>47</b>

## GENERAL INSTALLATION AND OPERATING INSTRUCTIONS

### 1.0 Important information

To ensure safety and correct operation please read and observe the following instructions carefully before proceeding. Important information is specified in the maintenance section on filter changes and necessary cleaning and maintenance activities. The user usually carries out maintenance work. The chapter “Installation” with important installation tips and basic unit adjustments is intended for the specialised installer.

**▲ The electrical connection must be fully isolated from the supply up to the final assembly!**

▲ This appliance is not intended for use by persons (including children) with reduced physical, sensory or mental capabilities, or lack of experience and knowledge, unless they have been given supervision or instruction concerning use of the appliance by a person responsible for their safety. Children should be supervised to ensure that they do not play with the appliance.

The planning office provides the planning documents necessary for system calculations. Additional information can be requested ex works. Keep the installation and operating instructions as a reference at the device. After the final assembly, the document must be handed out to the operator (tenant/owner).

### 1.1 Warning and safety instructions

**▲ The adjacent symbol is a safety-relevant prominent warning symbol. All safety regulations and/or symbols must be absolutely adhered to, so that any dangerous situation is avoided.**

### 1.2 Warranty claims – Exclusion of liability

If the preceding instructions are not observed, all warranty claims and accommodation treatment are excluded. This also applies to any liability claims extended to the manufacturer. The use of accessories not offered or recommended by AERA is not permitted. Potential damages are not covered by warranty.

### 1.3 Regulations – Guidelines

If the product is installed correctly and used to its intended purpose, it conforms to all applicable CE standards at its date of manufacture. The AERA AZURE ventilation units in this series are compliant with Eco-Design 2018.

# CHAPTER 1

## 1.4 Receipt

The delivery contains one of the following unit types:

Unit
AZURE 500
AZURE 700
AZURE 1400
AZURE 2200
AZURE 3200

The scope of delivery also includes:

4x Vibration pad

Please check delivery immediately on receipt for accuracy and damage. If damaged, please notify carrier immediately.

In case of delayed notification, any possible claim may be void.

## 1.5 Storage

When storing for a prolonged time the following steps are to be taken to avoid damaging influences: Protection by dry, air- dustproof packing. The storage place must be water protected, vibration-free and free of temperature variations. (Ambient temperature limit, min/max, 0°C/ +40°C) Damages due to improper transportation, storage or putting into operation are not covered by warranty.

## 1.6 Transport

The unit is packed ex works in a timber frame so that it is protected against normal transport strain. Carry out the shipping carefully. It is recommended to leave the unit in the original packaging until installation to avoid possible damages and soiling.

The transport must be carried out by trained and experienced personnel and the necessary safety precautions should be taken to prevent overturning and slipping of the device. During transport of the devices it should be ensured that the weight is evenly distributed over the four corners.

### **▲ Danger due to overhead loads – risk of grave injuries or death!**

- Never stand beneath suspended loads, since there is always a risk that the lifting gear, tackle, ropes or slings are faulty or damaged.
- Make sure that equipment is firmly seated before lifting it.

### **▲ Risk of injury! Watch out for nails when disassembling the timber frame!**

### **▲ Warning! Risk of personal injury and equipment damage!**

Due to a high center of gravity, some equipment can tend to tip over and cause damage to persons and property.

- When transporting the unit, carefully observe its behavior and do not get near any possible hazardous areas.

## 1.7 Intended use

AZURE devices are designed in 5 different models to correspond the need of up to 3200 m<sup>3</sup>/ h air flow. There is a ePM1 55% class filter on the fresh air side and a ePM10 50% class filter on the exhaust side as standard. The units are produced according to European Union energy criteria.

AZURE devices are designed with high energy efficient, low sound pressure and low power consumption plug fans. Plug fans with EC motors can be driven with 3 fixed speeds or steplessly with the help of an air quality sensor thanks to build in smart control system.

The AZURE units are equipped with counter flow heat exchangers, in which the heat of the extracted air is recovered and transferred through the plates to the incoming fresh external air, so both air flows remain separated. Through this procedure more than 80 % of the extract air heat is transferred to the external air. The supply air is led by the duct system to the primary (supply air needing) areas. The used air is extracted from the secondary areas (like e.g. social rooms, toilets, showers etc.). It flows back through the ducting to the ventilation unit, transfers the heat and is discharged by the exhaust air duct to the atmosphere.

The heat recovery efficiency depends on several factors, which include, among other things, air humidity and the temperature variation of outside air and exhaust air. The fan performance can be adjusted by the controller in scope of delivery. Various sensors e.g. CO<sub>2</sub> or humidity sensors (accessory) are available on request, with which automatic fan control is possible.

**▲** Permissible operating air temperature and humidity is 0/40 °C and 95% RH for AZURE units.

Electrical pre-heater (accessory) are used for preventing the cross counter flow heat exchanger from freezing at extremely cold outdoor temperatures. The summer bypass is the optimal solution for leading the colder outside air into the building in the warmer seasons. The installed filter optimally filters the air, which guarantees a hygienic unit and simultaneously ensures the service life of the compact unit.

Electrical after heater (accessory) used in AZURE devices. The electrical after heater is controlled by the desired supply air temperature. The temperature is chosen by the user.

# CHAPTER 1

Water after heater (accessory) are used for increasing the supply air temperature and for bringing the supply air to the desired temperature. Hot water coils can be driven by proportional control via 2 or 3-way valves.

Frost protection mechanism is available as standard to prevent the temperature of the supply water from reaching freezing conditions in extreme cold climates.

Water cooling coils and DX coils (accessory- not included in scope of delivery) are used for such purposes as lowering the blowing temperature and dehumidifying the air in the units. It can be driven either proportionally or by on / off method.

## **1.8 Performance data**

Mechanical connections must be made correctly in order to obtain maximum efficiency from the device. The device's thermal efficiency, sound level and electrical performance may vary depending on the ambient conditions the device is operating. These conditions may affect the measurement result on site and vary from the catalogue data.

## **1.9 Guideline series VDI 6022**

The AERA AZURE ventilation units in this series are produced compliant with VDI 6022. The guidelines range from operating regulations and material requirements through to construction regulations, which ensure high air quality. It must be ensured that only original AERA accessories are used for operation compliant with VDI 6022.

## **1.10 Heat systems**

The simultaneous use of controlled ventilation (AZURE units) and heat systems which depend on room air (tile oven, gas stove etc.) requires compliance with all applicable regulations.

The use of heat systems which depend on room air are only permitted in state-of-the-art dense apartments with separate combustion air supply; only then are AZURE and heat systems decoupled from each other and operable meeting the demands.

The relevant applicable regulations on the combined use of heat systems, domestic ventilation and extractor hoods (Federal Association of Chimney Sweeps (ZIV)) must be observed!

## 1.11 Technical Data

MODEL	AZURE				
	500	700	1400	2200	3200
Air flow (m <sup>3</sup> /h)	500	700	1400	2200	3200
Rated current – ventilation (A)	3	3	4,3	6,8	11,3
Rated current – pre-heating (A)	7	3,3	6,5	10,2	15,2
Rated current – after-heating (A)	7	3,3	6,5	10,2	15,2
Max. total rated current (A)	10,5	4,9	8,7	13,6	20,8
Power consumption – ventilation(kW)		8,2x8,2x7,3	15,2x15,2x13,6	23,8x23,8x21	36x36x30,9
Power consumption – pre-heating (kW)	1,6	2,3	4,5	7,05	10,5
Power consumption – after-heating (kW)	1,6	2,3	4,5	7,05	10,5
Max. power consumption (kW)	3,7	5,1	10,1	15,8	23,7
Voltage/Frequency	1~230V 50Hz	3~400V 50Hz	3~400V 50Hz	3~400V 50Hz	3~400V 50Hz
Filter class (extract / outdoor air)	ePM10 50% -M5 / ePM1 55% - F7	ePM10 50% -M5 / ePM1 55% - F7	ePM10 50% -M5 / ePM1 55% - F7	ePM10 50% -M5 / ePM1 55% - F7	ePM10 50% -M5 / ePM1 55% - F7
Weight (kg)	130	155	200	285	370
Sound pressure (dB)	56	54	57	53	58
Standby losses	< 1W	< 1W	< 1W	< 1W	< 1W
IP Class	IP20	IP20	IP20	IP20	IP20
Wiring diagram	Fig. 54-55-56	Fig. 57-58-59	Fig. 60-61-62	Fig. 63-64-65	Fig. 66-67-68

# CHAPTER 1

EcoDesign Points	AZURE				
	500	700	1400	2200	3200
Declared typology	Bidirectional	Bidirectional	Bidirectional	Bidirectional	Bidirectional
Type of drive	Variable	Variable	Variable	Variable	Variable
Type of HRS	Recuperative	Recuperative	Recuperative	Recuperative	Recuperative
Nominal NRVVU flow rate [ m <sup>3</sup> /h ] / Pressure drop [Pa]	500 / 100	700 / 100	1400 / 200	2200 / 200	3200 / 250
Max. ecodesign flow rate [ m <sup>3</sup> /h ] / Pressure drop [Pa]	615 / 78	850 / 0	1550 / 248	2450 / 251	3250 / 392
Thermal efficiency of heat recovery at nominal airflow [ % ]	82,4	82,4	81,1	82,3	83,1
Thermal efficiency of heat recovery at max. ecodesign point [ % ]	81,1	81,4	80,6	81,8	83
Static efficiency of fans at max. ecodesign point [ % ]	44,3	51,1	57,6	57,6	53,2
Face velocity at nominal airflow [ m/s ]	1,4	1,6	2,2	2,13	2,21
Internal pressure drop at max. ecodesign point [ Pa ]	81	96	112	108	97
Internal total pressure drop at max. ecodesign point [ Pa ]	285	286	359	355	331
SFP int at max. ecodesign point [ W/(m <sup>3</sup> /s) ]	1297	1081	1251	1240	1248
SFP int_limit at max. ecodesign point [ W/(m <sup>3</sup> /s) ]	1317	1317	1263	1262	1265
Declared maximum external leakage [ % ]					
Declared maximum internal leakage [ % ]					
Description of visual filter warning	Pressure controlled	Pressure controlled	Pressure controlled	Pressure controlled	Pressure controlled
Casing sound power level (Lwa) [ dB(A) ]					
ErP Compliance	2018	2018	2018	2018	2018

## 1.12 Disassembly and re-assembly

Mechanical connections must be made correctly in order to obtain maximum efficiency from the device. The device's thermal efficiency, sound level and electrical performance may vary depending on the ambient conditions the device is operating. These conditions may affect the measurement result on site and vary from the catalogue data.

**WARNING**  **Before starting any disassembly or re-assembly operation, please ensure that the product is isolated from its mains electrical supply, in order to ensure that fans cannot be run. As disassembly and re-assembly are not part of routine maintenance, these should be carried out by qualified personnel.**



⚠ Ensure the unit is voltage-free and isolated, earth and short circuit the unit, cover or shield off neighbouring live components. Ensure that the hydraulic circuit is switched off.

⚠ Close all hydraulic shut-off valves.

Isolate all connections and ensure leak-free condition regarding oil, refrigerant  
As the coil piping diameter is small, waste water can remain in the unit following normal evacuation. For safety reasons, use compressed air to blow through the system in order to remove all remaining water.

**WARNING** ⚠

**Risk of personal injury and equipment damage!**

Due to a high center of gravity, some equipment can tend to tip over and cause damage to persons and property.

⚠ When transporting the unit, carefully observe its behaviour and do not get near any possible hazardous areas.

## 1.13 Disposal

**WARNING** ⚠

**Before starting any operation, please ensure that the product is isolated from its mains electrical supply, in order to ensure that fans cannot be run.**

⚠ Dispose of all components and filters and disused operating materials (e.g. oil, refrigerants) in an environmentally-friendly manner in accordance with the local codes, practices and environmental regulations.

An authorized appointed contractor specializing in waste processing must dispose of the unit or its individual components. This appointed contractor must ensure that:

- the components are separated according to material types
- the used operating materials are sorted and separated according to their respective properties.

# CHAPTER 2

## INSTALLATION

### 2.0 Assembly

AZURE compact devices are suitable for ceiling mounting thanks to the hanging apparatuses found on. Due to noise level which change according to working conditions, it is recommended to install the AZURE units in the different rooms. Ensure that there is a waste water connection in the installation area. Please consider the information on the “condensation outlet”! Assembly should take place in such a way to enable preferably short ventilation ducts and their trouble-free connection to the unit. Tight bends in the channel will cause high pressure drops.

#### **Important notes:**

1. The ventilation ducts must not become kinked.
2. The connections to the connection valves must be firm and tight.
3. Flange connections must be leakproof and firm
4. The terminal box is connected to the side of the casing and maintenance and service space should be left for the doing any work on the device.
5. The assembly of the AZURE compact unit must only take place in rooms that are free of frost, as there is a danger of freezing. The room temperature must not fall below +5 °C
6. In order to prevent sound transmission, appropriate acoustic decoupling must be provided on site depending on the building material.

### 2.1 Ceiling installation

**▲ DANGER TO LIFE!** Before installing the compact unit, it must be ensured that the ceiling and/or the fixing components used can withstand the heavy weight and vibration of the AZURE unit. Unsuitable mounting material can lead to the unit falling uncontrollably from the ceiling. There is danger to life due to the heavy weight! Furthermore, it can also lead to a large amount of property damage! Depending on the mounting, a further safeguard must be implemented to safeguard the AZURE compact unit from falling uncontrollably!

Four mounting brackets (with vibration pads (standard unit delivery)) (Fig.1) are mounted to the unit for ceiling installation. Installation to the ceiling takes place e.g. with hanger bolts or suitable mounting accessories.

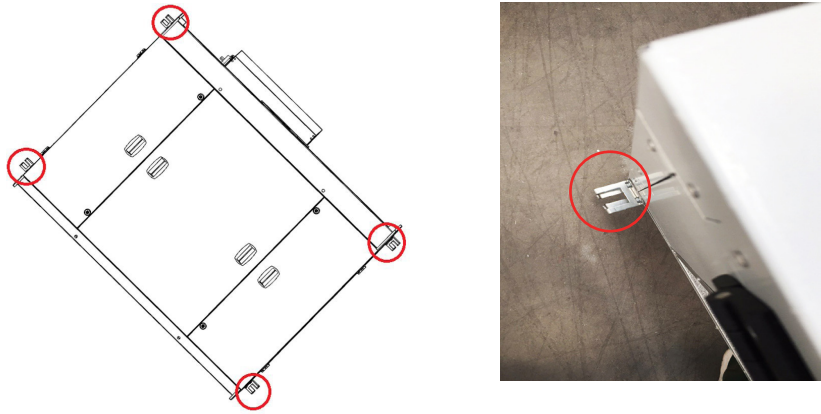

Fig.1

**▲ When installing to ceiling, it is recommended that the heat exchanger is removed from the unit to reduce the installation weight when lifting.**

**Assembly area**

Observe the following criteria during installation to ensure that the device service is comfortable. (Fig. 2)

A is the minimum distance for opening service cover.

C is the minimum distance for servicing the terminal box.

**ATTENTION** ⚠ In assemblies where the minimum distance A is not available, the service doors can be removed from the hinges.

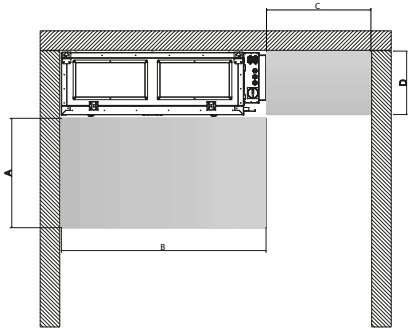

MODEL	A	B	C	D
	Dimensions (mm)			
AZURE 500	665	1050	600	383
AZURE 700	666	1225	600	385
AZURE 1400	703	1525	600	425
AZURE 2200	757	1895	600	508
AZURE 3200	797	2145	600	594

# CHAPTER 2

## 2.2 Condensation outlet

The humidity of exhaust air condenses to water during the heating period. A lot of condensate can build up in new buildings with large numbers of people. The condensate water collected in the condensate tub made of stainless steel. (The condensate water can discharge via a ball siphon (accessory)).

**ATTENTION** ⚠

The drainage pipe route must not rise above the siphon!

Condensate water can be easily removed from the condensate tube. If the water is to be raised to a certain height, a suitable pump should be used. (7.6 Condensate pump)

The condensation outlet must be made frost-proof with proper insulation.

## 2.3 Flange connection / adapter pieces

AZURE flange connection diameters are shown below (Fig. 3)

**ATTENTION** ⚠

Fixing sheet metal must be used for flange connection in AZURE 3200. (included in scope of flange delivery.)

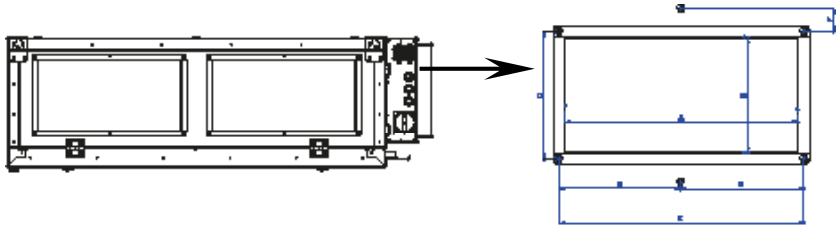

Fig.3

Unit type	Dimensions (mm)						
	A	B	C	D	n	E	F
<b>AZURE 500</b>	300	150	320	170	0	-	-
<b>AZURE 700</b>	400	200	420	220	0	-	-
<b>AZURE 1400</b>	500	250	520	270	0	-	-
<b>AZURE 2200</b>	500	300	520	320	0	-	-
<b>AZURE 3200</b>	700	400	720	420	1	360	30
<b>n : number of drill hole (horizontal) (Except corner holes)</b>							
<b>Hole/Bolt dimension: M8X20</b>							

**Adapter pieces for ducts are available from AERA.**

**NOTE**

The piping must be firmly and tightly connected to the connection valves. Refer to the illustrations for the arrangement of ventilation ducting.

## 2.4 Air ducting, Ventilation circuit

When designing the ductwork, use the shortest possible runs. Airtight connections and changeovers must be ensured for the best possible heat recovery. To avoid pressure losses, dirt build-up and noise, use smooth ducts (plastic or rigid ducting). Exhaust and outside air pipes are to be insulated in an appropriate way to reduce condensation. The minimum insulating thicknesses pursuant to DIN EN 1946-6, are to be observed. If supply and extract air ductwork runs through unheated rooms, insulation must be provided to reduce heat losses.

A filter (accessory) is to be connected for the extraction of polluted extract air. The installation of extractor hoods to the system is not permitted (reasons: dirt, fire danger, hygiene).

**All fire and building regulations must be observed!**

**WARNING** 

## 2.5 Electrical connection

**The unit must be fully isolated from the mains power supply before any maintenance and installation work or before opening the enclosure! The electrical connection must only be carried out by an authorised qualified electrician in accordance with the following wiring diagrams. The electrical connection must be fully isolated from the mains power supply until the assembly is complete!**

## CHAPTER 2

The unit is equipped with a main switch and an isolator which can be secured against unauthorized switching with a U-lock.

The relevant standards, safety regulations (e.g. DIN VDE 0100) and the technical connection conditions of the local electricity supply companies must be observed. An all-pole mains switch / isolator, with a contact opening of at least 3 mm (VDE 0700 T1 7.12.2 / EN 60335-1) must be provided. The main switch and/or isolator can be secured against unauthorized switching with a U-lock.

The surface-mounted controller with touchscreen is connected to the unit by means of a 5 m connecting cable (also available in 10 or 20 m length). The electrical connection of the AZURE takes place directly in the terminal box. If any electronic accessory is added the unit, the electrical connections must be made in the terminal box.

▲ These circuit breakers recommended from the manufacturer for the AZURE units below.

AZURE	500	700	1400	2200	3200
Phase	1+1	3+1	3+1	3+1	3+1
Type	C	C	C	C	C
Circuit Breaker (A)	20	8	16	25	40

▲ For the leakage current protection manufacturer recommended 30mA residual current device.

## FUNCTIONAL DESCRIPTION

### 3.0 Unit Description (Fig. 4)

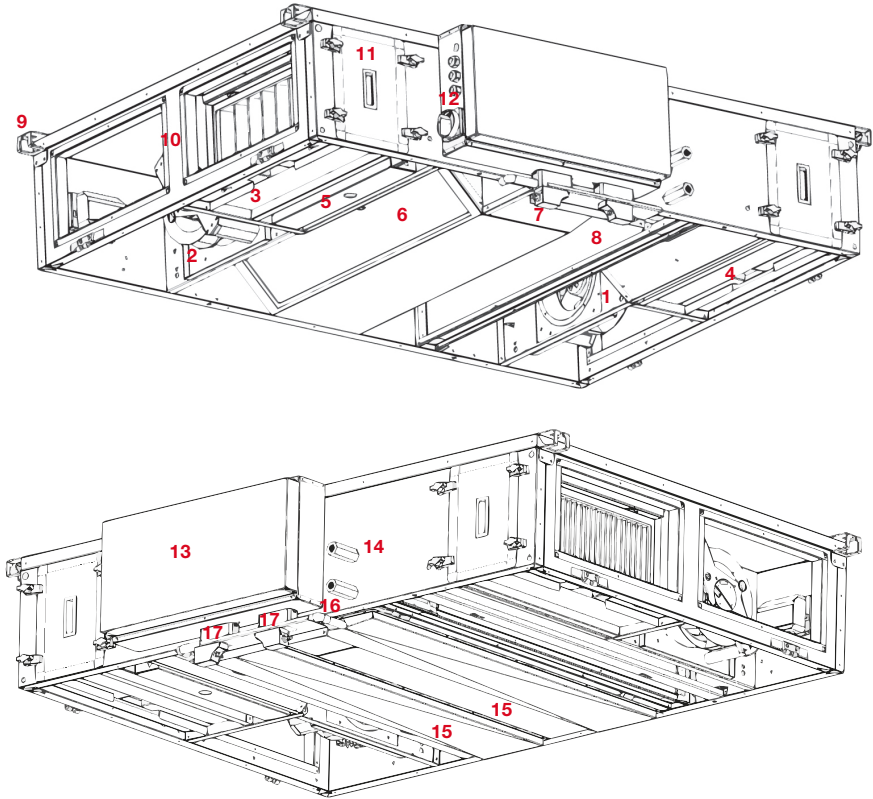

- |  |                                    |
|--|------------------------------------|
| 1. Supply Fan  | 10. Casing                         |
| 2. Exhaust Fan   | 11. Filter service cover           |
| 3. Outdoor Air Filter (ePM1 55%)                           | 12. Main switch                    |
| 4. Extract Air Filter (ePM10 50%)                          | 13. Terminal box                   |
| 5. Electrical Pre-heater (optional)                        | 14. Water after heater outlet      |
| 6. Counter Flow Heat Exchanger                             | 15. Drain pan                      |
| 7. Bypass (not visible)                                    | 16. Condensation outlet (3/8 inch) |
| 8. Electrical After Heater / water after heater (optional) | 17. Drain pump (optional)          |
| 9. Mounting Bracket  |                                    |

# CHAPTER 3

## 3.1 Functional Diagram (Fig. 5)

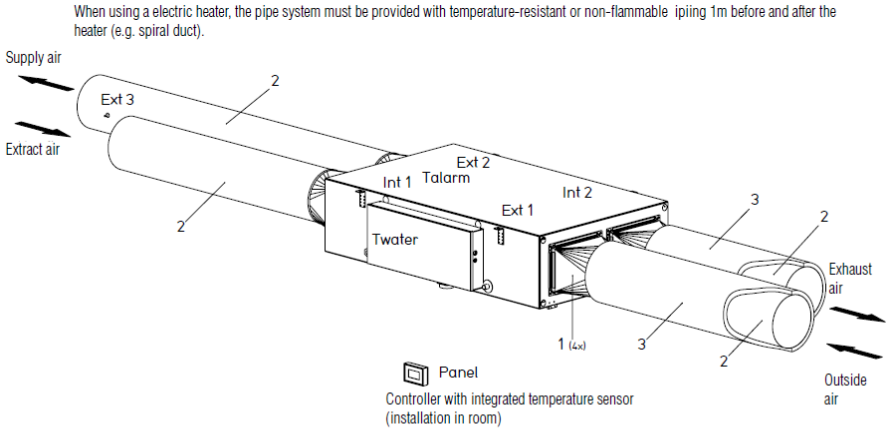

Fig. KWL EC 700D PRO WW

Pos.	Name	Ref. no.
Ext 1	Outside air sensor	-----
Ext 2	Supply air sensor	-----
Int 1	Extract air sensor	-----
Int 2	Exhaust air sensor/frost-protection sensor WT	-----
Talarm	Frost-protection sensor WW heater (only for WW unit types)	-----
Twater	Frost-protection sensor WW heater return (only for WW unit types)	-----
Ext 3	Duct sensor (ventilation unit scope of delivery)	-----
Panel	Controller with integrated temp. sensor incl. connection cable RJ12 (5m length)	-----
1	Adapter piece KWL-US 700 D	04206
	Adapter piece KWL-US 1400 D	04207
	Adapter piece KWL-US 2000 D	04208
2	Temperature-resistant or non-flammable piping (e.g. spiral duct)	-----
3	Temperature-resistant or non-flammable insulation	-----



## DIMENSIONS PERFORMANCE CURVE

### 4.0 Dimensions (Fig. 6)

MODEL	A	B	C	D	E	F	G	K	L	X	Y
	Dimensions (mm)										
AZURE 500	1540	383	465	674	399	920	130	820	1578	300	150
AZURE 700	1590	385	466	749	372	1095	130	995	1628	400	200
AZURE 1400	1715	425	503	799	410	1395	130	1295	1753	500	250
AZURE 2200	1940	508	557	932	448	1765	130	1665	1978	500	300
AZURE 3200	2090	594	597	967	523	2015	130	1915	2128	700	400

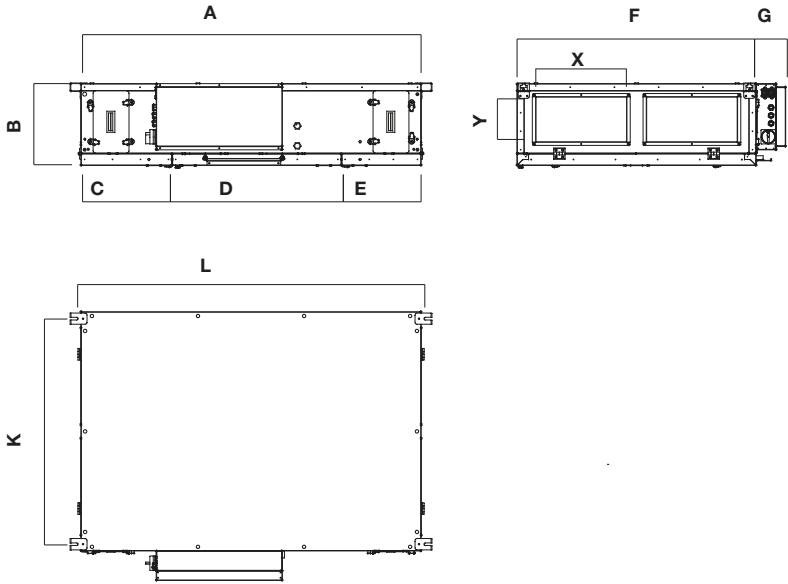
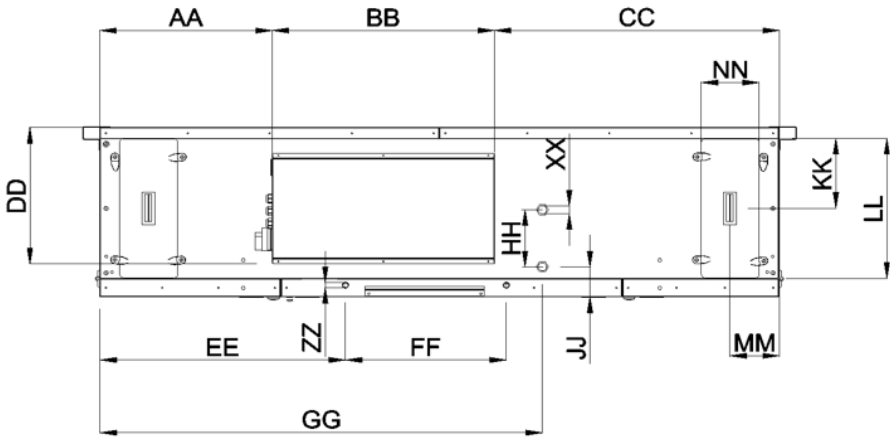

Fig.6

# CHAPTER 4

MODEL	AA	BB	CC	DD	EE	FF	GG	HH	JJ	KK	LL
	Dimensions (mm) (Fig. 7)										
AZURE 500	394	521	625	313	613	296	964	65	88	133	275
AZURE 700	399	556	635	315	615	338	1024	88	86	135	277
AZURE 1400	419	606	690	337	653	373	1118	116	85	155	317
AZURE 2200	539	606	795	430	737	436	1275	163	89	200	400
AZURE 3200	614	606	870	502	776	436	1379	197	87	243	486

MODEL	MM	NN	PP	RR	SS	TT	UU	YY	ZZ	XX	LL
	Dimensions (mm) (Fig. 7)										
AZURE 500	177	206	320	170	254	412	191	36.5	3/8 inch	1/2 inch	275
AZURE 700	177	206	420	220	300	487	203	36.5	3/8 inch	1/2 inch	277
AZURE 1400	177	206	520	270	395	605	223	36.5	3/8 inch	1/2 inch	317
AZURE 2200	177	206	520	320	454	854	254	36.5	3/8 inch	1/2 inch	400
AZURE 3200	177	206	720	420	530	955	315	36.5	3/8 inch	3/4 inch	486



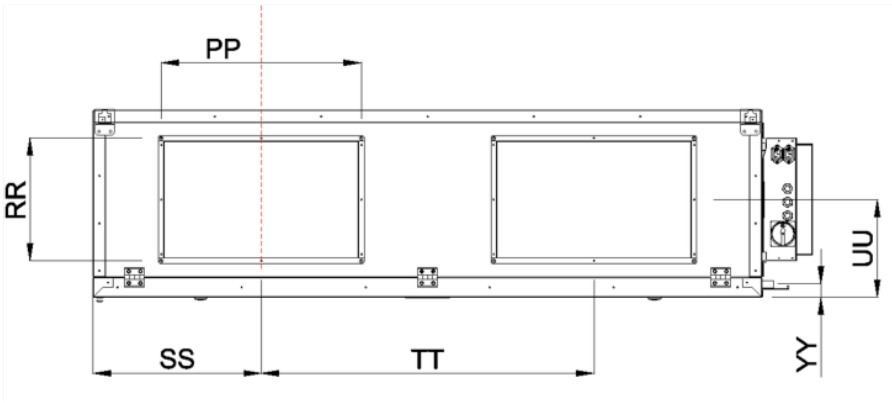
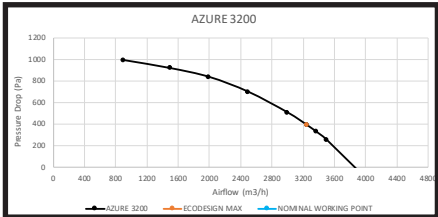
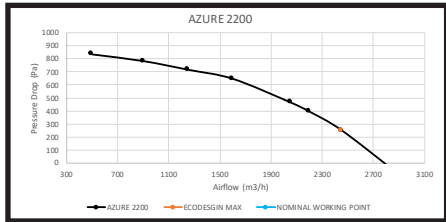
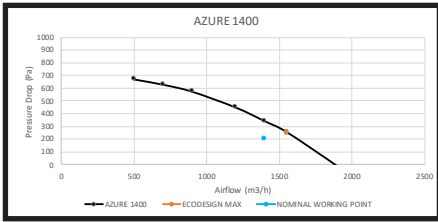
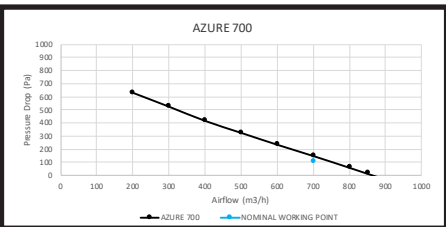
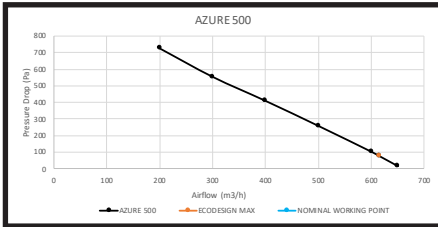

Fig.7

## 4.1 Performance curves



# CHAPTER 5

## SERVICE AND MAINTENANCE

### 5.0 Service and maintenance

The filter change is usually carried out by the user. Additional cleaning and maintenance work must only be carried out by qualified electricians.

**WARNING** 

**⚠ The unit must be disconnected from the power supply before any maintenance and installation work! Danger of electric shock, moving parts (fan) and hot surfaces.**

### 5.1 Removing/cleaning cross counter flow heat exchanger

**⚠ DANGER OF INJURY!** From falling or down-folding covers/inspection openings! Maintenance and service work should always be carried out by two people! Heat exchanger is heavy!

**⚠ RISK OF INJURY! High weight! Two people are required for dismantling the AZURE units.**

Unit	Counter-flow heat exchanger weight (kg)
AZURE 500	10,1
AZURE 700	14,6
AZURE 1400	23,6
AZURE 2200	39,2
AZURE 3200	62,2

**ATTENTION** 

**⚠ The heat exchangers of AZURE 2200, AZURE 3200 devices are in two parts.**

**⚠** If a drain pump is installed, disconnect the drain pump connections before servicing the heat exchanger.

1. Unlock and open the service covers. Support the panel with your hand while opening (Fig. 8)
2. Unscrew the screws of the middle service cover. (Fig. 9)
3. Remove the service panel by pulling towards the electrical box. (The panel will remove after exiting the slots.) (Fig. 10)
4. Unscrew all screws from the heat exchanger sheet metal cover. (Fig. 11)
5. Loosen the heat exchanger star knob from the heat exchanger fixing sheet metal. (Fig. 12) **Support heat exchanger with your hand!**
6. Carefully pull heat exchanger from the unit. (Fig. 13)



(Fig. 9)

# CHAPTER 5



(Fig. 10)



(Fig. 11)



(Fig. 12)



(Fig. 13)

**▲** The counter-flow heat exchanger must be inspected regularly for dirt and dust deposits. If there are dirt and dust deposits on the heat exchanger, these can be easily removed, using one of the following methods;

**Cleaning pressure:** up to 5 bar

**Temperature:** 70°C

- Aluminium counter-flow heat exchanger can be wet cleaned and up to a pressure of 5 bar working pressure.
  - The cleaning can be made with cold or warm (up to max. 70°C) water. Household cleaners are allowed.
  - Clean heat exchanger on both sides!
  - Do not bend the fins!
  - Recuperators are corrosion and weather resistant.
  - When cleaning take care that the exchanger is not damaged, neither mechanically nor chemically.
- Allow heat exchanger to dry before installation!**

## 5.2 Filter change

**▲ Make sure that the power connection is disconnected before doing any work on the device.**

**Danger of electric shock; moving parts (fan) and hot surfaces.**

The inspection openings on the ventilation unit enable the easy change of outdoor filter and exhaust air filter.

**▲ Filters can be removed from the side of the device or from service doors under the device.**

**ATTENTION** 

**▲ The filters of AZURE 1400, AZURE 2200, AZURE 3200 devices are divided in two parts**

**WARNING** 

**▲ RISK OF INJURY!** From down-folding covers /inspection openings!

1. Unlock and open the service covers. Support the panel with your hand while opening (Fig. 14)
2. Slide the filter lock to the right (Fig.15)
3. Carefully remove filter (Fig.16)

**▲ The filter's direction of air flow must be taken into account!**

# CHAPTER 5



(Fig. 14)



(Fig. 15)

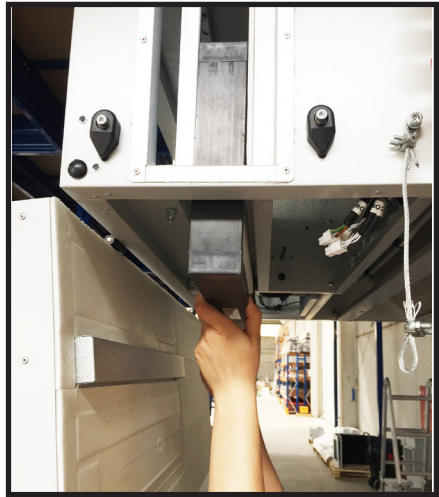

(Fig. 16)



1. Filter service doors are on the side of the device
2. Loosen the screws of the filter service cover (Fig. 17)
3. Remove the service cover completely (Fig. 18)
4. Pull filter lock (Fig. 19)
5. Remove filter from slides (Fig. 20)

**⚠ The filter's direction of air flow must be taken into account!**

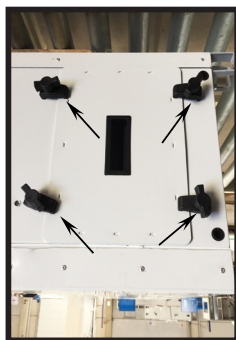

(Fig. 17)



(Fig. 18)

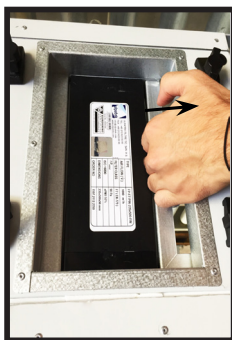

(Fig. 19)

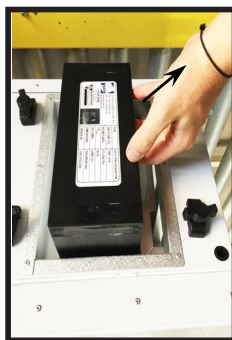

(Fig. 20)

## Filter

The AZURE compact unit is equipped with ePM1 55% (F7) class filter on the outdoor air side and **ePM1 50% (M5) class filter on the extract air side as standard.**

### Outside/extract air:

Filter Name	Filter Type	Ref. no.
AZURE 500 Extract air filter	ELF-AZURE500/ePM10 50% - M5/96	No.
AZURE 500 Outdoor air filter	ELF-AZURE500/ePM1 55% - F7 /96	No.
AZURE 700 Extract air filter	ELF-AZURE700/ePM10 50% - M5/96	No.
AZURE 700 Outdoor air filter	ELF-AZURE700/ePM1 55% - F7 /96	No.
AZURE 1400 Extract air filter	ELF-AZURE1400/ePM10 50% - M5/96	No.
AZURE 1400 Outdoor air filter	ELF-AZURE1400/ePM1 55% - F7 /96	No.
AZURE 2200 Extract air filter	ELF-AZURE2200/ePM10 50% - M5/96	No.
AZURE 2200 Outdoor air filter	ELF-AZURE2200/ePM1 55% - F7 /96	No.
AZURE 3200 Extract air filter	ELF-AZURE3200/ePM10 50% - M5/96	No.
AZURE 3200 Outdoor air filter	ELF-AZURE3200/ePM1 55% - F7 /96	No.

# CHAPTER 5

The filters must be regularly checked (see controller display factory setting every 6 months) for degree of soiling (danger of mould formation). They must be exchanged for hygiene reasons through one-off extraction or after one year of operation at the latest. If the filters are damp or mouldy, they must be exchanged immediately.

Replacement air filters are also available online at [www.ersatzluftfilter.de](http://www.ersatzluftfilter.de)

## 5.3 Service and maintenance of fans

**WARNING**  **RISK OF INJURY!** Make sure that the power connection is disconnected, and fan is not moving before doing any work on the device.

1. Unlock and open the service covers. Support the panel with your hand while opening (Fig. 21)
2. Unplug the power connector of the fan (Fig. 22)
3. Remove the fan pressure hoses (Fig. 23)
4. Remove the fan star knob (Fig. 24)
5. Remove the fan slowly and carefully (Fig. 25)
6. Be careful to electrical connections when installing the fans back into



(Fig. 21)



(Fig. 22)

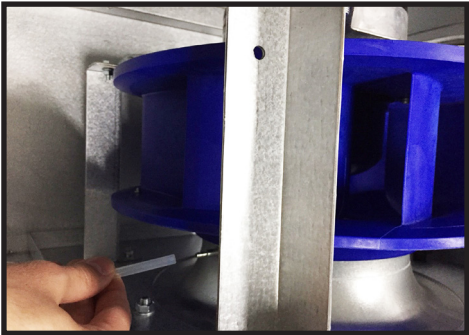
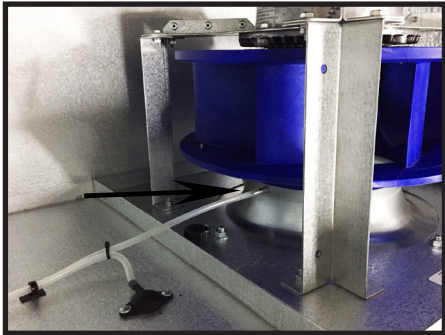

(Fig. 23)

# CHAPTER 5





(Fig. 24)



(Fig. 25)

## 5.4 Service and maintenance of pre-electrical heater

**WARNING**  **RISK OF INJURY!** Make sure that the power connection is disconnected, and fan is not moving before doing any work on the device.

 Danger of electric shock; moving parts (fan) and hot surfaces.

1. Unlock and open the service covers. Support the panel with your hand while opening (Fig. 26)
2. Unplug the electrical connections on the electrical heater (Fig. 27)
3. Remove the pre-electrical heater star knob. Support the electrical heater with your hand while removing star knob (Fig. 28)
4. Remove the pre-electrical heater slowly and carefully (Fig. 29)
5. Be careful to electrical connections when installing the pre-electrical heater back into



(Fig. 26)

# CHAPTER 5



(Fig. 27)



(Fig. 28)



(Fig. 29)

## 5.5 Pre-electrical Heater Reset function

Manual reset button is located directly on the electrical pre-heater

**WARNING** 

**RISK OF INJURY! The unit must be disconnected from the power supply before any maintenance and installation work or before opening the compartment!**

1. Unlock and open the service covers. Support the panel with your hand while opening (Fig. 30)
2. Press the reset button to reset pre-electrical heater (Fig. 31)



(Fig. 30)





(Fig. 31)

-  **Manual reset: 90°C**
-  **Automatically reset: 70°**

# CHAPTER 5

## 5.6 Condensate tray Cleaning

**WARNING**  **RISK OF INJURY! The unit must be disconnected from the power supply before any maintenance and installation work or before opening the compartment!**

 If a drain pump is installed, disconnect the drain pump connections before removing the service panel.

1. Unlock and open the service covers. Support the panel with your hand while opening (Fig. 32)
2. Unscrew the screws of the middle service cover. (Fig. 33)
3. Remove the service panel by pulling towards the electrical box. (The panel will remove after exiting the slots.) (Fig. 34)
4. Clean condensate tray with a cloth (Fig. 35)



(Fig. 32)





(Fig. 33)

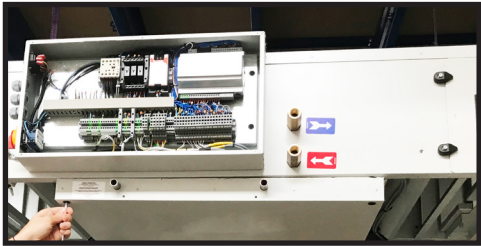

(Fig. 34)



(Fig. 35)

**5.7 Terminal box with isolator/main switch**

The terminal box that is connected to the side of the casing ensures free access to the electronic component.

# CHAPTER 6

## Installations, service and maintenance of accessories

### 6.1 Accessory list

<b>Accessories</b>
Air filter (ePM1 80% - F9 / 96mm)
Electrical Pre-Heater
Electrical After Heater
Water After Heater (Right)
Cooling Water Coil (Right)
Cooling DX Coil (Right)
Outdoor Damper
Duct Adapter
Flexible Connection
Sound Attenuator
Condensate Pump
E3-DSP Display
ED-T7 Display
Presigo CAP-Modus
HMI Connection Cable (10m or 20m)
Siphon
Heater Siphon for Outside Installation
Signal Converter
Hydraulic Kit (WHSH)
Thermostat - STB 70 (Pre- / Afterheater)
Thermostat - STB 90 (Pre- / Afterheater)

## 6.2 Installation of water after heater

Make sure that the power connection is disconnected before doing any work on the device.

- ⚠ Danger of electric shock; moving parts (fan) and hot surfaces.
- ⚠ **Refer to the electrical diagrams for hot water coil signal connections.**

1. Unlock and open the service covers. Support the panel with your hand while opening (Fig. 36)
2. Unscrew the screws of the middle service cover. (Fig. 37)
3. Remove the service panel by pulling towards the electrical box. (The panel will remove after exiting the slots.) (Fig. 38)
4. Remove the coil pipe fitting. (Fig. 39)
5. Place the hot water coil and attach the star knobs (Fig. 40)
6. Connect the coil water outlet to the pipe fitting (Use contra tightening method to prevent any damage to the piping system) (Fig. 41)
7. Place the temperature sensor on the water outlet pipe with the metal cable tie (metal cable tie is included in scope of hot water coil delivery) (Fig. 42)
8. Connect the coil water inlet to the pipe fitting, (Use contra tightening method to prevent any damage to the piping system)



(Fig. 36)

# CHAPTER 6



(Fig. 37)



(Fig. 38)



(Fig. 39)



(Fig. 40)



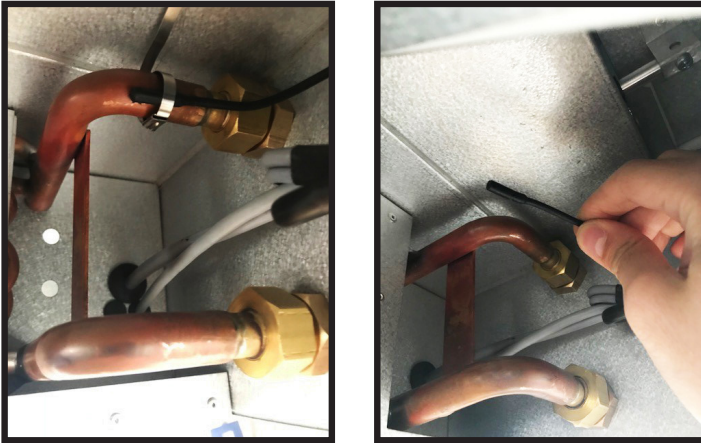

(Fig. 41)

# CHAPTER 6



(Fig. 42)

## 6.3 Installation of electrical after heater

**WARNING**  **RISK OF INJURY!** Make sure that the power connection is disconnected, and fan is not moving before doing any work on the device.  
 Danger of electric shock; moving parts (fan) and hot surfaces.

1. Unlock and open the service covers. Support the panel with your hand while opening (Fig. 43)
2. Remove the support sheet metal (Fig. 44)
3. Place the electrical after heater and attach the star knobs (Fig. 45)
4. Plug the electrical connections on the electrical heater (Fig. 46)

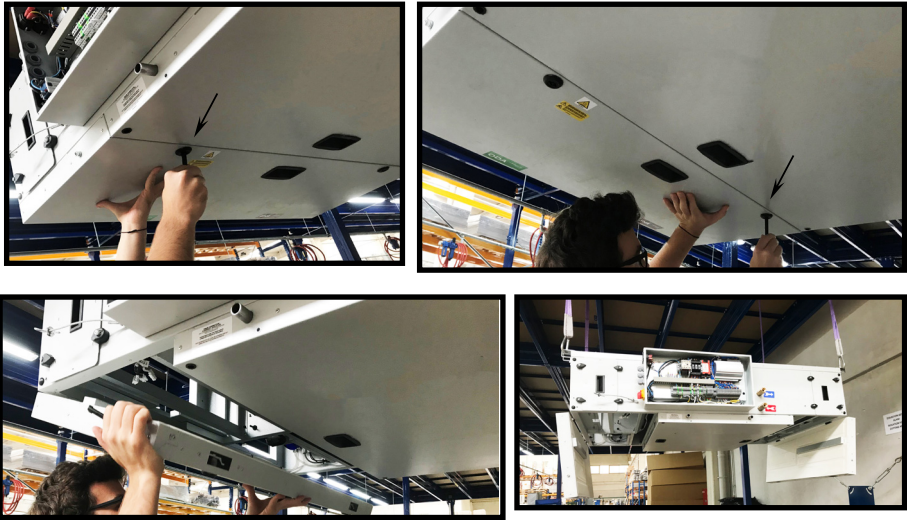

(Fig. 43)

# CHAPTER 6

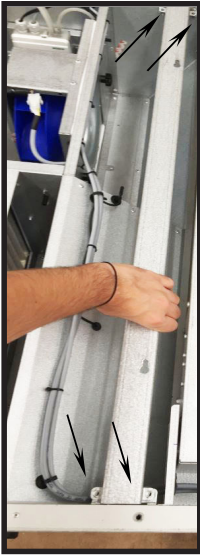

(Fig. 44)



(Fig. 45)



(Fig. 46)



## Reset function

Manual reset lever is located directly on the electrical pre-heater.

**WARNING** ⚠

**RISK OF INJURY! The unit must be disconnected from the power supply before any maintenance and installation work or before opening the compartment!**

1. Unlock and open the service covers. Support the panel with your hand while opening (Fig. 47)
2. Pull the reset button to reset after-electrical heater (Fig. 48)



(Fig. 47)



(Fig. 48)

# CHAPTER 6

## 6.4 Installation of condensate pump:

Condensate water can be easily removed from the condensate tube. If the water is to be raised to a certain height, a suitable pump should be used.

1. See figure 49 to determine the amount of condensate water in each AZURE models (Fig. 49)
2. See figure 50 and 51 to determine the height at which the pump can send water. (Fig. 50 for AZURE 500, AZURE 700, AZURE 1400) (Fig. 51 for AZURE 2200, AZURE 3200)

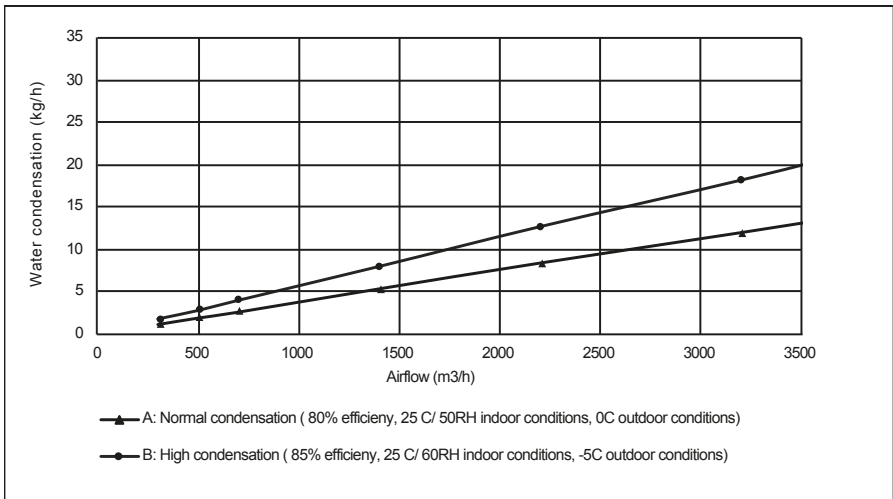

(Fig. 49)

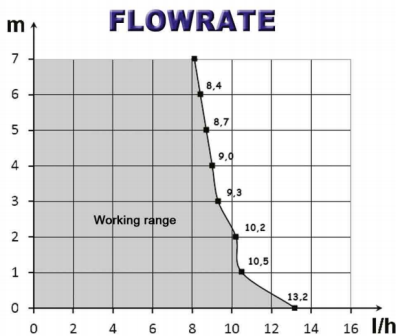

(Fig. 50)

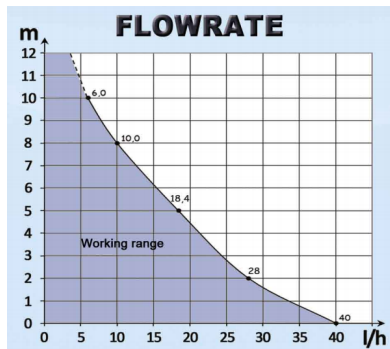

(Fig. 51)



# CHAPTER 7

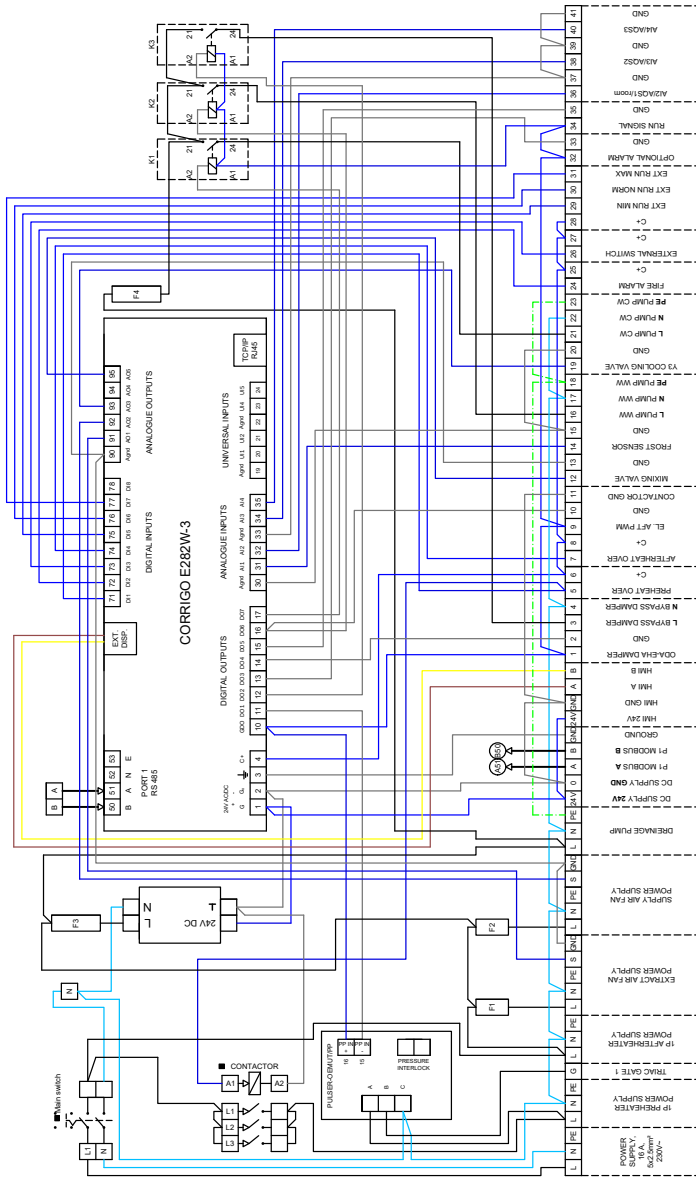

**AZURE 500 CONTROL PANEL DIAGRAM**  
 (Fig. 53)



# CHAPTER 7

## 7.2 AZURE 700 Wiring Diagram

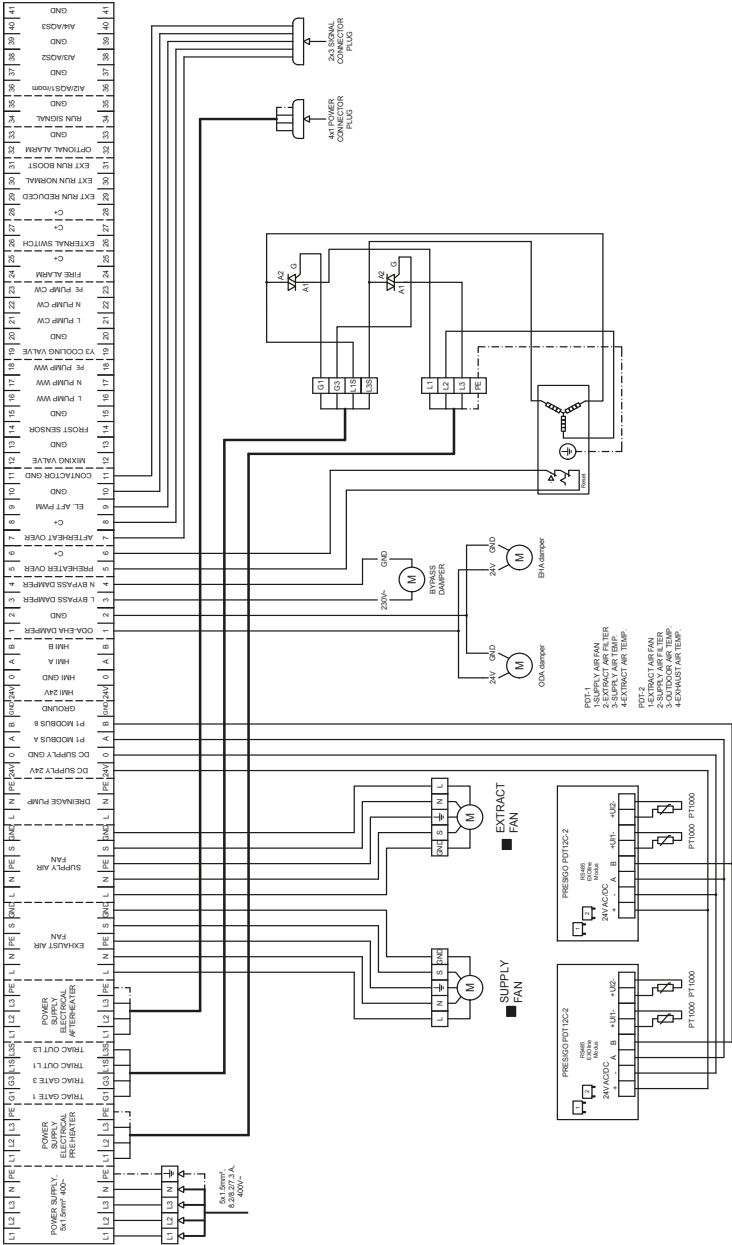

AZURE 700 STANDART UNIT WIRING DIAGRAM

(Fig. 55)









# CHAPTER 7

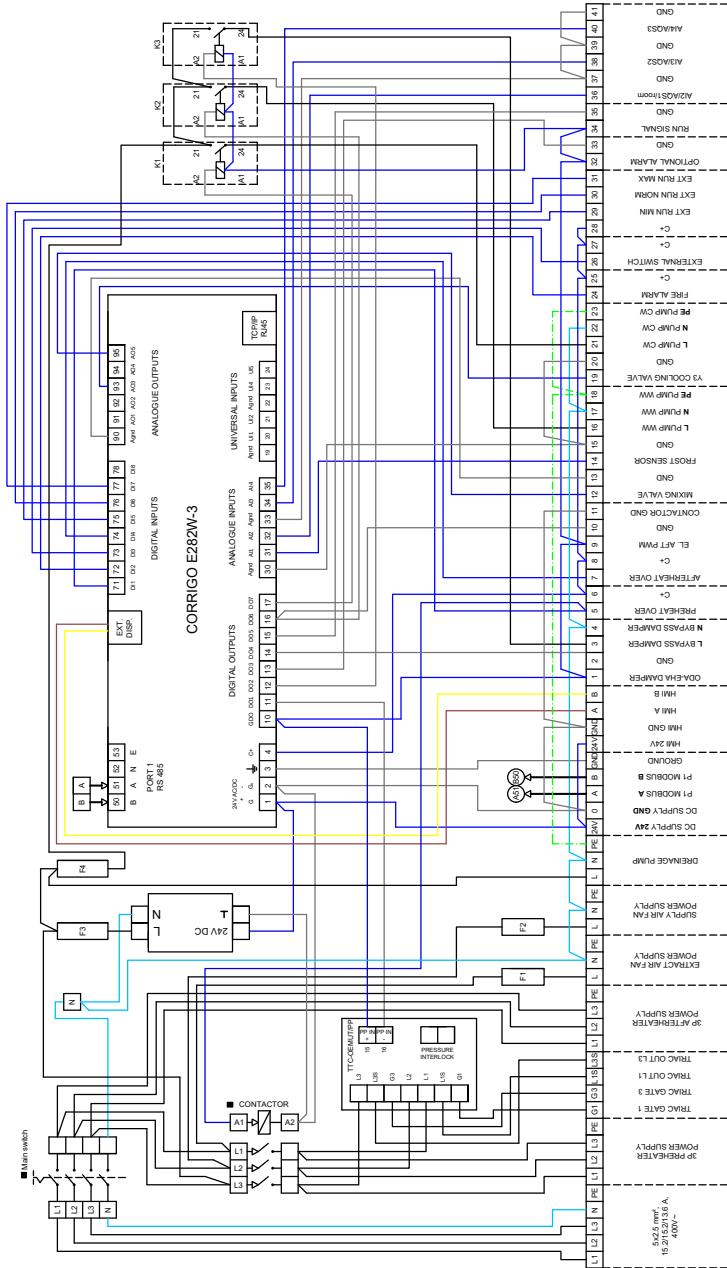

**AZURE 1400 CONTROL PANEL WIRING DIAGRAM**

(Fig. 59)

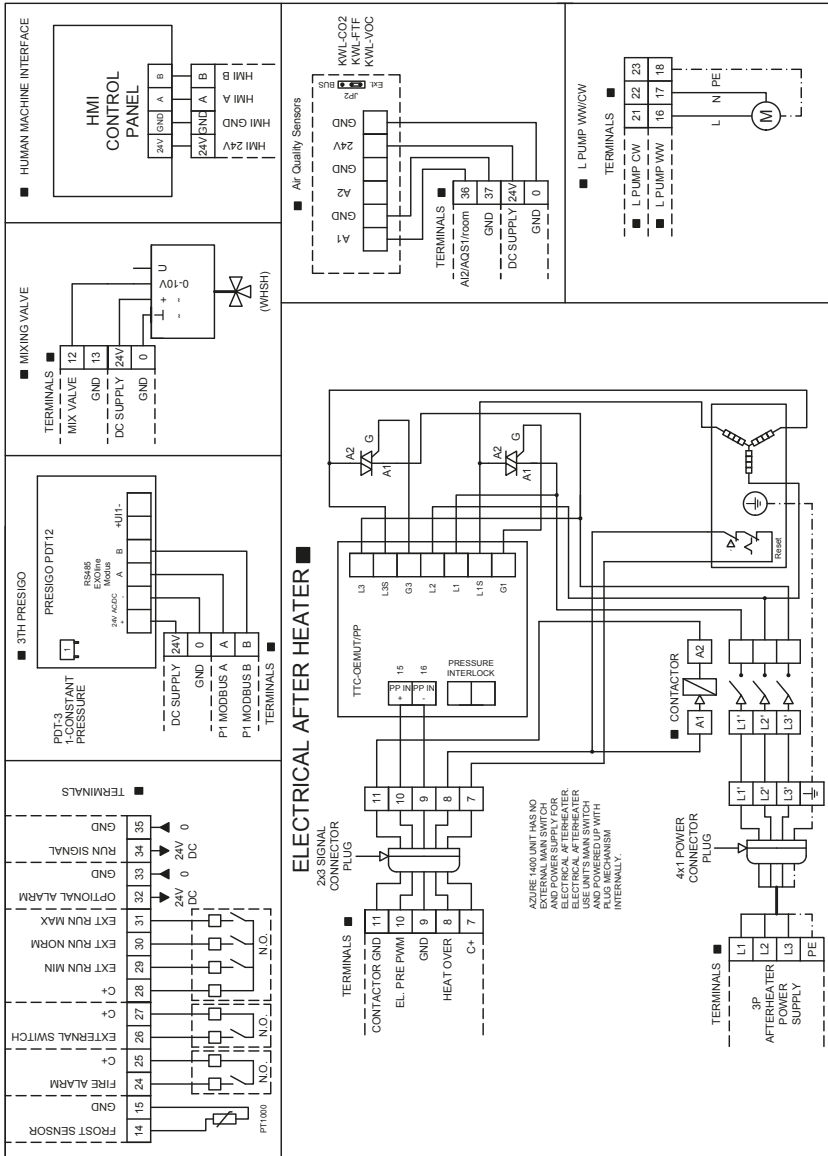

**AZURE 1400 ACCESSORIES DIAGRAM (Fig. 60)**

# CHAPTER 7

## 7.4 AZURE 2200 Wiring Diagrams

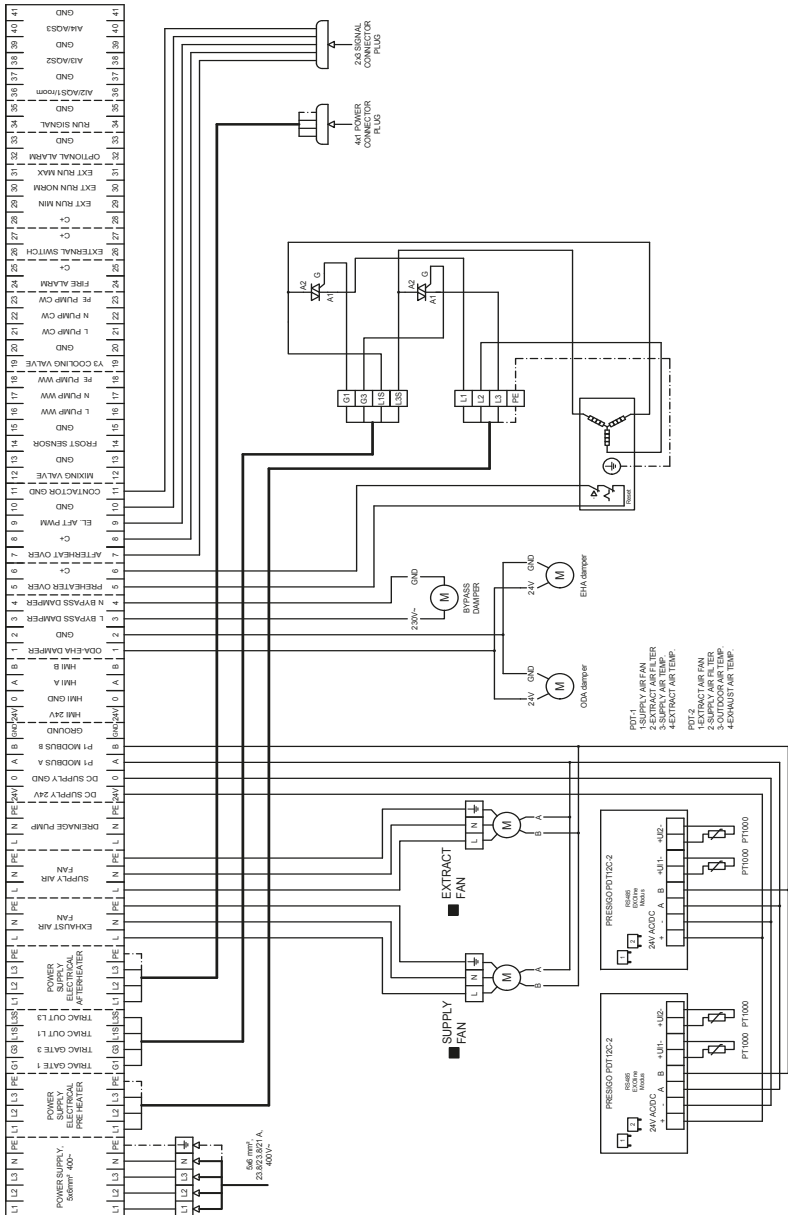

AZURE 2200 STANDARD UNIT WIRING DIAGRAM  
(Fig. 61)





## 7.5 AZURE 3200 Wiring Diagrams

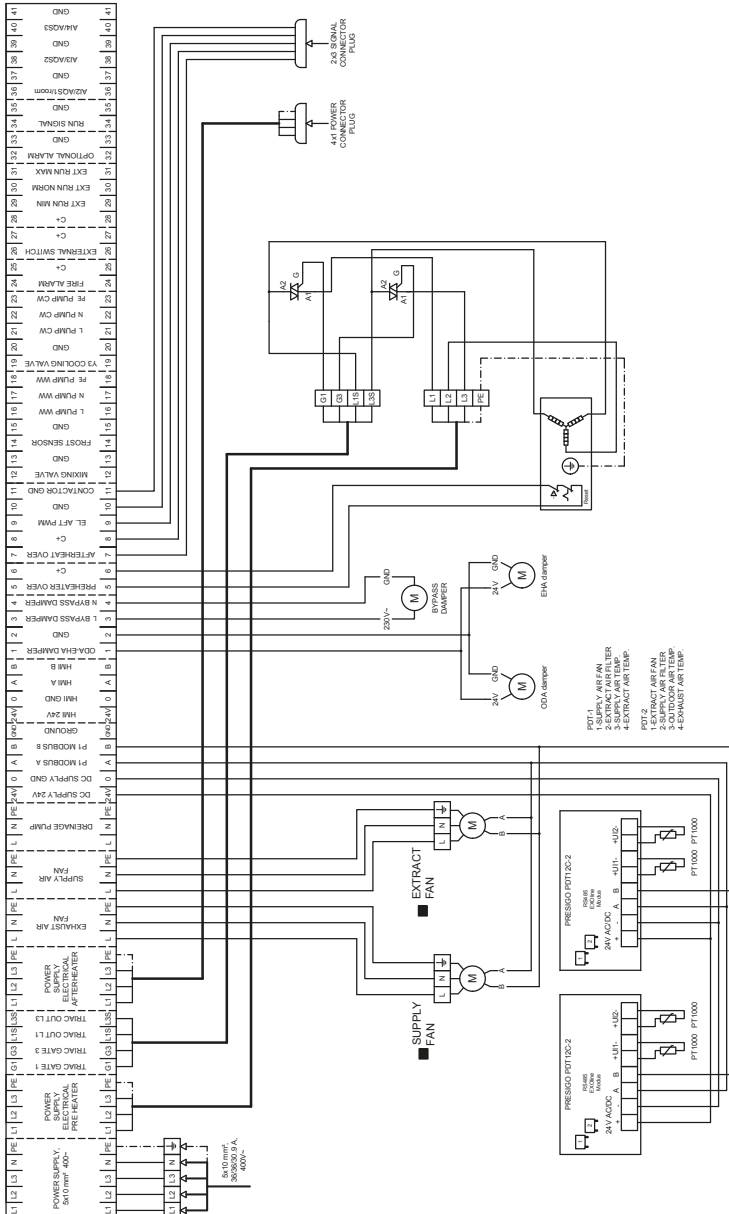

AZURE 3200 STANDARD UNIT WIRING DIAGRAM (Fig. 64)







# CHAPTER 8

## SPARE PART LIST

You may use only original AERA spare parts are allowed, since AERA is not liable if any third party spare components are used.

<b>Spare Part</b>
Exhaust Air Fan Assembly
Fresh Air Fan Assembly
Star knob for fan fixation
Heat Exchanger
Heat Exchanger - Fixing sheet metal
Main PCB
Presigo PCB
Main Transformer
Fuse
Fuse holder
Main switch
Terminal box (Cover)
Terminal box (mainpart w/ top hat rail)
Terminal box P/A H
HMI Connection Cable (5m)
Contactor
TTC Triac + Controller
Relais (Bypass-motor / WW/CW pump)
Bypass-Actuator
Air Temperature Sensor (PT1000)
Service Panel hinge
Service Panel Lock
Filter Service Door
Door (Small Left)
Door (Small Right)
Door (Big Middle)
Suspension
Vibration Pad
Extract air filter (ePM10 50% - M5/96mm)
Outdoor air filter (ePM1 55% - F7 /96mm)

## After Sales Service

AERA heat recovery devices do not have any parts replacement or repair work to be performed by the user other than cleaning and eye inspection. Users should contact the AERA company for faults detected during operation or maintenance. If you have problems and need to get a service, please contact the following address.



---

### FACTORY

■ ■ ■

3. Cadde No:13 Pancar OSB, Torbalı - İzmir  
TEL +90 232 799 0 111 FAKS +90 232 799 01 14

**User's**  
Manual

# AZURE

COUNTER FLOW  
HEAT RECOVERY  
VENTILATION

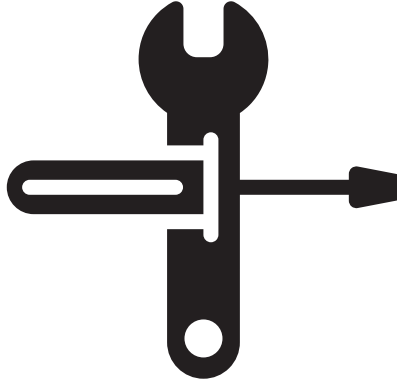

**AERA AIR CONDITIONING & VENTILATION TECH.**

**Sales Office** ■ Varyap Meridian, Grand Tower A Blok No:89 Ataşehir İSTANBUL

TEL +90 216 504 76 86 FAX +90 216 504 76 90

**Factory** ■ 3. Cadde No:13 Pancar OSB, Torbalı - İzmir

TEL +90 232 799 0 111 FAX +90 232 799 01 14

[aera.com.tr](http://aera.com.tr)

